



3M™ Liqui-Cel™ EXF-10×28 Series Membrane Contactor

Assembly and Disassembly Instructions

TABLE OF CONTENTS

I. Safety and Warning	3
II. Assembly Parts	4
III. Part Orientation	4
IV. Assembly Tools	5
V. End Cap Removal	6
VI. Cartridge Insertion	7
VII. End Cap Preparation / Installation	9
Manual Insertion	9
Vacuum Insertion	10
IX. Center Seal Tightening	11
X. Pressure Test	11

SAFETY INFORMATION

Read, understand, and follow all safety information contained in these instructions prior to the use of this 3M™ Liqui-Cel™ Membrane Contactor. Retain these instructions for future reference.

Intended Use:

This Liqui-Cel Membrane Contactor is intended to add to or remove dissolved gases from non-dangerous liquid streams. It is expected that all users be fully trained in the safe operation of membrane contactors. Membrane contactors are intended for installation and operation by qualified installers and operators in accordance with all operating guidelines, installation instructions, and any other industry requirements. Use in any other application may not have been evaluated by 3M and may lead to an unsafe condition.

WARNING

To reduce the risks associated with explosion:

- Only use replacement parts supplied by 3M for this product.

To reduce the risks associated with crush or impact related injuries:

- Always ensure the membrane contactor is properly secured. Be sure the membrane contactor cannot tip, roll, fall, slide or make any movement that may cause injury or damage to other system components.
- No liquid, vacuum or sweep gas should be running through the contactor when changing cartridges or other parts. Membrane contactors should be completely drained of liquid before attempting to service.
- Care must be taken not to hit or jar (shock) the membrane contactor.

To reduce the risks associated with lifting or moving:

- Always consult the product datasheet or operating guide for membrane contactor weights. Use appropriately rated lifting equipment for lifting or moving heavy membrane contactors.
- Drain liquid from the contactor before moving. **Do not** move a membrane contactor while it contains liquid.

CAUTION



To reduce the risks associated with environmental contamination:

- At the end of useable life, dispose of the membrane contactor or cartridges in accordance with local regulations and laws.





NOTICE

- The membrane contactor(s) should not be stored where they are exposed to direct sunlight. Membrane contactors should always be stored in sealed bags or shrink wrap material and in the original box or other opaque box.
- Store dry membrane contactor(s) at temperatures < 49° C (120° F) with low to moderate humidity levels (<60% relative humidity).
- Avoid contact with surfactants/solvents or oxidants (e.g. ozone, chlorine) to prevent wet-out or oxidation of the hydrophobic membrane.
- To avoid contamination, gloves are recommended when handling the membrane cartridges.
- **Do not** use dope or metal connections to connect to plastic connections of the membrane contactor.
- Failure to follow any instructions in this guide will void any warranty, if any exists.

EXPLANATION OF SIGNAL WORD CONSEQUENCES

 WARNING	Indicates a potentially hazardous situation, which, if not avoided, could result in death or serious injury and/or property damage.
 CAUTION	Indicates a potentially hazardous situation, which, if not avoided, could result in minor or moderate injury and/or property damage.
NOTICE	Indicates a potentially hazardous situation, which, if not avoided, could result in property damage.

EXPLANATION OF SAFETY AND RELATED SYMBOLS

	Warning: Explosion
	Warning: Crush or Impact
	Caution: Lifting or Moving Hazard
	Caution: Possible Environmental Impact

ASSEMBLY PARTS

- A. O-rings (4)
 - Inner O-ring To seal the cartridge into the housing, this 7.5 mm O-ring is the shellside or liquid side O-ring.
 - Outer O-ring To seal the cartridge into the end cap, this 6.9 mm O-ring is the lumenside or gas side O-ring.
- B. Lock ring (2) An elastomeric ring used to position the inner shellside O-ring.
- C. Center Seal (2) To seal the center tube of cartridge and center nozzle of the end cap.
- D. Center Seal Washer To protect the center seal during tightening. (not shown)
- E. L Washer To compress the center seal during tightening. (not shown)

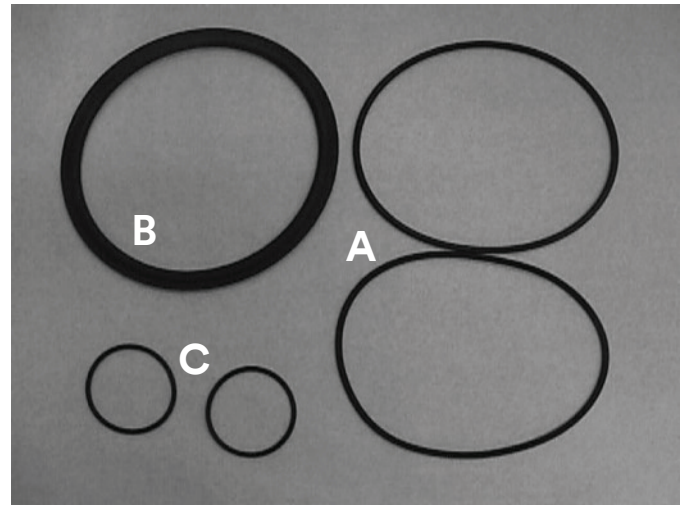

PART ORIENTATION

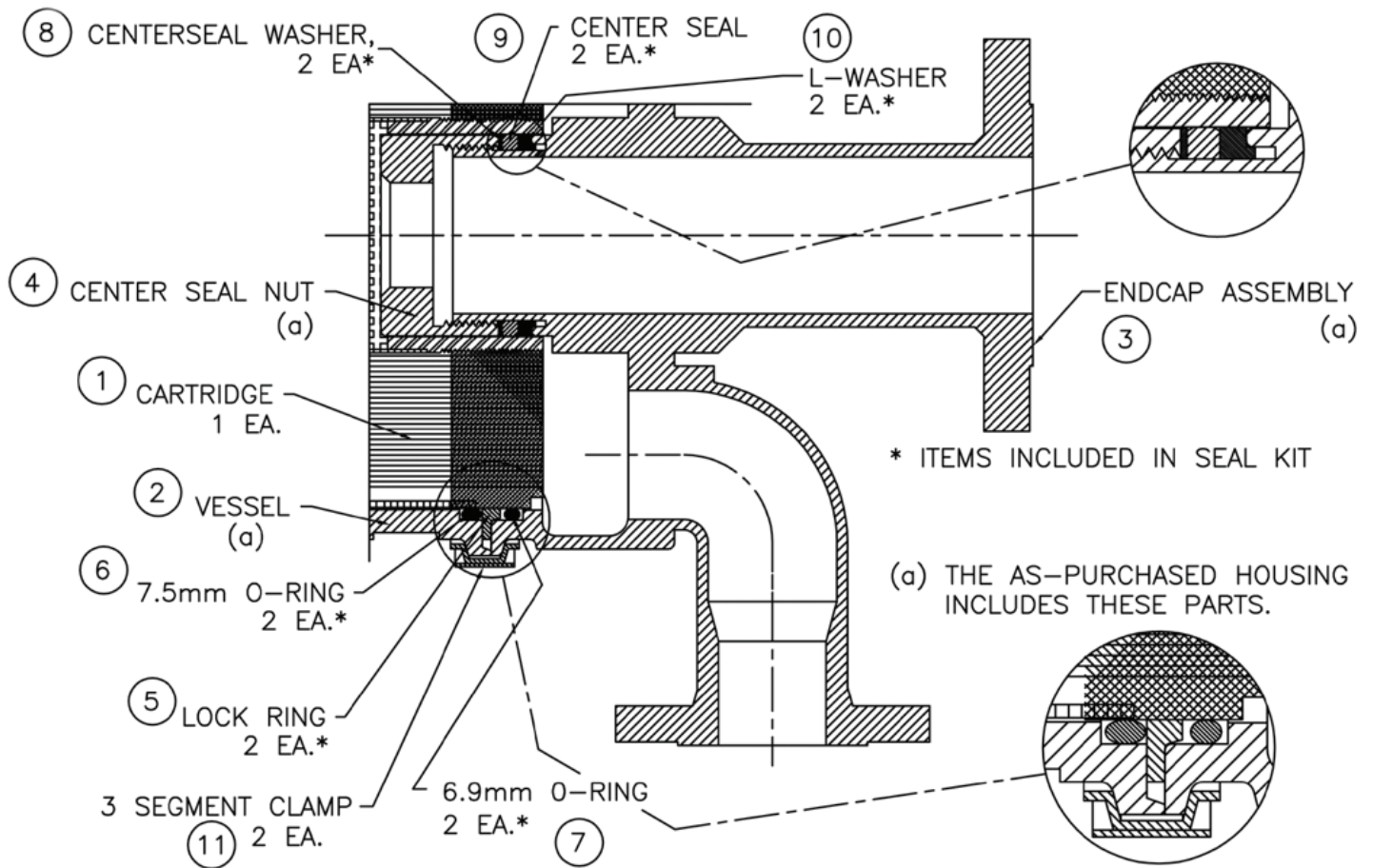

ASSEMBLY TOOLS

10 × 28 Change-Out Tools

- Rubber Mallet** Used to tap T-handle during inner O-ring insertion.
- T-Handle** Used to insert inner (shellside) O-ring during assembly.
- O-ring Pick** Used to remove the inner (shellside) O-ring during disassembly.
- Center Seal Tool** Used to loosen / tighten *Center Seal Nut*.
- Allen Wrench** Used to change protective bushing and socket (plastic parts) on Center Seal Tool.

- Reversible Torque Wrench with 3/4 inch (19 mm)** Fits onto hexagonal rod on the Center Seal Tool (not included with kit).

- Cartridge Alignment Tool** Used to align the cartridge with the housing.

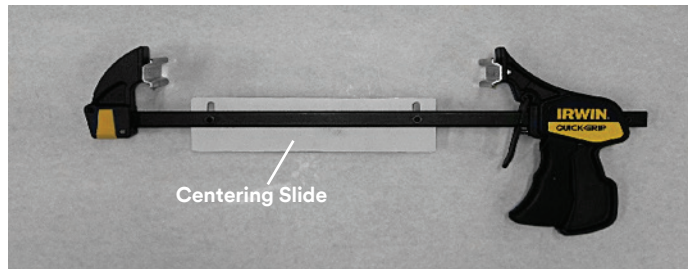
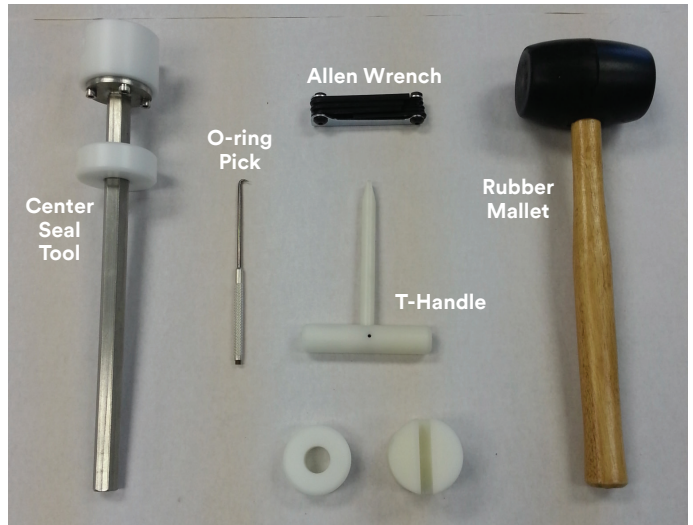

10 × 28 Change-Out Tools

A complete assembly tool kit will include four (4) sets of the following:

- Assembly Rods** Threaded rod that will be screwed together to make a complete assembly tool.
- Assembly Clips** Dark machined parts that slide over the Assembly Rods.

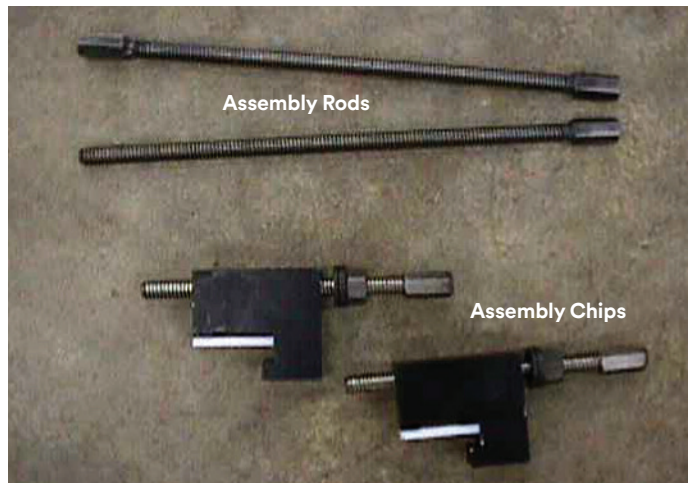

The equipment illustrated above is required for the assembly or disassembly of a 3M™ Liqui-Cel™ EXF-10×28 Series Membrane Contactor that will be assembled in a 316L SS Housing.

END CAP REMOVAL

WARNING

To reduce the risks associated with crush or impact related injuries:

- Always ensure the membrane contactor is properly secured. Be sure the membrane contactor cannot tip, roll, fall, slide or make any movement that may cause injury or damage to other system components.
- No liquid, vacuum or sweep gas should be running through the contactor when changing cartridges or other parts. Membrane contactors should be completely drained of liquid before attempting to service.
- Care must be taken not to hit or jar (shock) the membrane contactor.

To reduce the risks associated with lifting or moving:

- Always consult the product datasheet or operating guide for membrane contactor weights. Use appropriately rated lifting equipment for lifting or moving heavy membrane contactors.
- Drain liquid from the contactor before moving. **Do not** move a membrane contactor while it contains liquid.

CAUTION

To reduce the risks associated with environmental contamination:

- At the end of useable life, dispose of the membrane contactor or cartridges in accordance with local regulations and laws.

NOTICE

- To avoid contamination, gloves are recommended when handling the membrane cartridges.

END CAP REMOVAL STEPS

- (A) Place the contactor horizontally. Insert the center seal tool into the center nozzle. Slowly loosen the center seal nut by turning in a clockwise direction 2 rotations.
- Loosen the V-Band clamp. Remove the nut from the V-band clamp and remove the clamp from the assembly.

NOTE: Using ISO Ashby Cross oil on the nut will help get the nut on and off more easily.

- (B) Using a permanent marker place 2 small alignment marks, one on the housing and one on the end cap. This will allow the end cap to be reassembled in the same position.
- Move end cap up and down, and left and right until it becomes loose. Remove end cap and set aside. It may also be necessary to insert a prybar or screwdriver into the space between the end cap and housing to separate the two pieces.
- **EXTREME CAUTION** must be used to ensure that the epoxy surface of the contactor is not damaged. Be sure to keep the end cap with same end of the housing to allow proper realignment upon reassembly.
- Remove all seal elements between the cartridge and the housing. It will be necessary to use the O-ring pick to remove the inner (shellside) O-ring. Discard used O-rings.

Repeat all of the above steps for each end of the contactor.

A

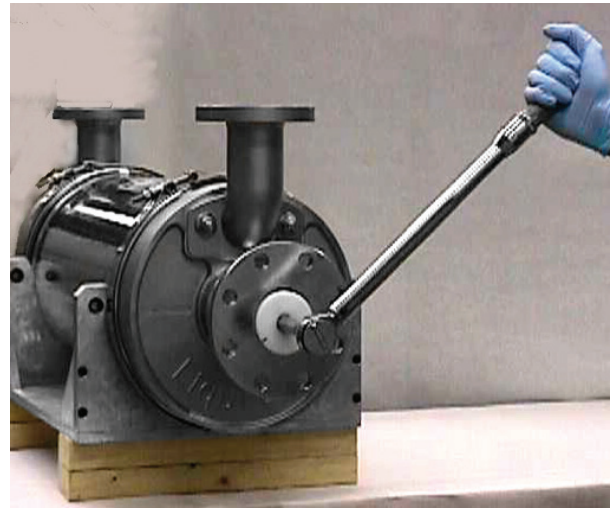



B



CARTRIDGE INSERTION

WARNING

-  **To reduce the risks associated with explosion:**
 - Only use replacement parts supplied by 3M for this product.
-  **To reduce the risks associated with crush or impact related injuries:**
 - Always ensure the membrane contactor is properly secured. Be sure the membrane contactor cannot tip, roll, fall, slide or make any movement that may cause injury or damage to other system components.
 - Care must be taken not to hit or jar (shock) the membrane contactor.
-  **To reduce the risks associated with lifting or moving:**
 - Always consult the product datasheet or operating guide for membrane contactor weights. Use appropriately rated lifting equipment for lifting or moving heavy membrane contactors.

NOTICE

- To avoid contamination, gloves are recommended when handling the membrane cartridges.

CARTRIDGE INSERTION STEPS

- (A) Carefully clean the sealing surfaces of the housing and the cartridge.
- Slide the cartridge into the housing leaving the epoxy equally exposed on each end.
NOTE: Be careful not to chip the epoxy edge of the contactor.
- Review the Assembly Parts and Part Orientation drawing to become familiar with the part location and terminology.
- (B) Check to be sure that the cartridge is centered in the housing. Look at and feel both ends to ensure proper alignment.
- Measure both ends using a ruler to assure the membrane cartridge is centered in the housing.
- (C) Loosen the wing nuts on the centering slide on the cartridge alignment tool.
- Clamp the cartridge alignment tool on one end of the housing.
- Move slide until it is flush against the face of the cartridge and tighten wing nuts.
- Check to make sure the cartridge is still centered. Use a ruler if necessary.
- If adjusting is necessary, it must be done now before O-rings are inserted completely.
- (D) Starting at the end opposite the alignment tool, place the 7.5 mm shellside O-ring around the outside of the cartridge.
- Lift the cartridge slightly and use the T-handle insertion tool to press the O-ring into the space between the housing wall and the epoxy sealing surface of the contactor at the 6 o'clock position (see diagram 1).
- Recheck cartridge alignment.
- Once the alignment is acceptable, continue to set the O-rings in the 12 o'clock, 3 o'clock and 9 o'clock positions using the T-handle insertion tool.

A

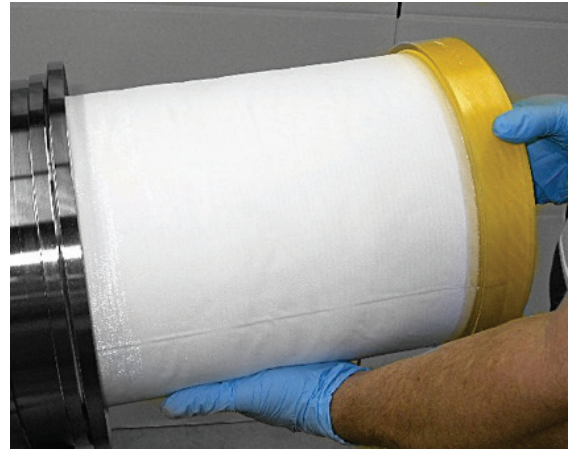

B



C

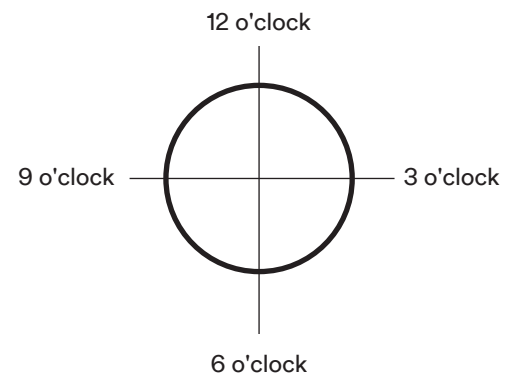

Diagram 1

- (E) Use the T-Handle insertion tool to press in the remaining O-ring sections. When inserting the O-rings, it is best to always divide each section of un-inserted O-ring in half and press in the middle section. See the photograph to the right, for an example.
- When the 7.5 mm O-ring is completely inserted, remove the cartridge alignment tool.
- Repeat the same process on opposite end of cartridge.

NOTE: If the O-ring is ever pinched or cut it **MUST** be removed and discarded.

E



F

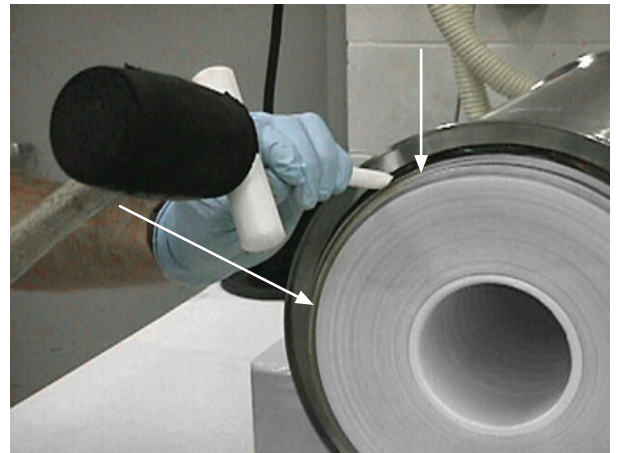

- (F) After the O-ring has been inserted where these arrows point, use insertion tool as pictured.

G

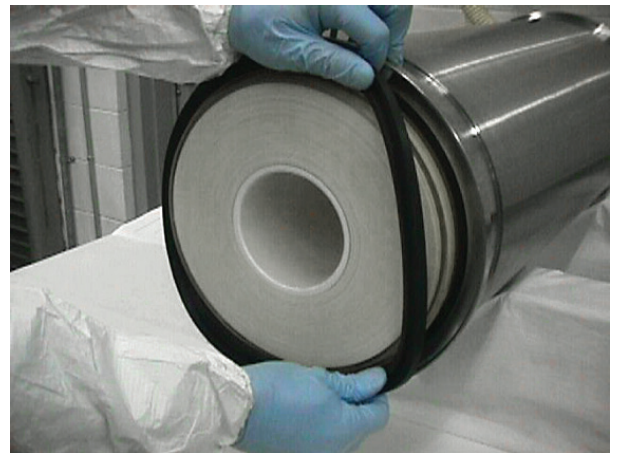

- (G) Place the lock ring around the outside of the cartridge. (See Assembly Part "b" on page 3).

H

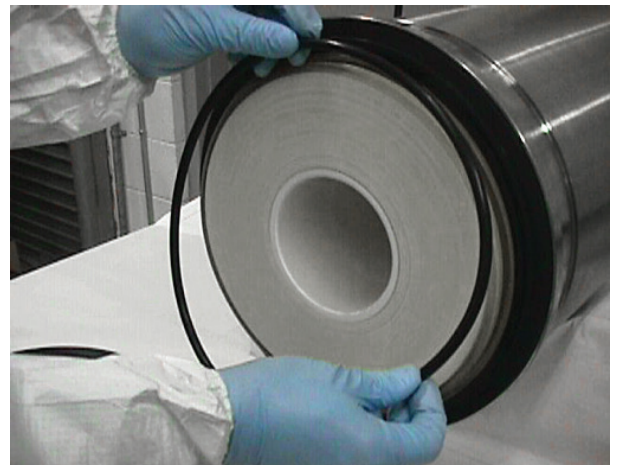

- (H) Place the outer O-ring (6.9 mm) on the lumen epoxy sealing surface. If the O-ring appears to be rolled or twisted, please adjust the position so the O-ring sits flat on the epoxy. (See Assembly Part "a" on page 3).

Repeat these steps on the opposite end of the cartridge.

END CAP PREPARATION/INSTALLATION

WARNING

To reduce the risks associated with explosion:

- Only use replacement parts supplied by 3M for this product.

To reduce the risks associated with crush or impact related injuries:

- Always ensure the membrane contactor is properly secured. Be sure the membrane contactor cannot tip, roll, fall, slide or make any movement that may cause injury or damage to other system components.
- Care must be taken not to hit or jar (shock) the membrane contactor.

To reduce the risks associated with lifting or moving:

- Always consult the product datasheet or operating guide for membrane contactor weights. Use appropriately rated lifting equipment for lifting or moving heavy membrane contactors.

NOTICE

- To avoid contamination, gloves are recommended when handling the membrane cartridges.

There are two options for inserting an end cap. Option 1 is Manual Insertion, option 2 is Vacuum Insertion. Determine your method of choice and go to that section.

MANUAL INSERTION

- (A) Inspect and clean the sealing surface of both end caps.
- Place L washer around the center nozzle and press it down until it touches the cap nut.
- Place the center seal (see Assembly Part "d" on page 3) on the center nozzle. Press it over the threads and down against the L washer. Place the center seal washer (thinner washer) over the threads and against the center seal (see Assembly Parts "e" on page 3). Screw the center seal nut onto the nozzle. Once it touches the washer, loosen one turn.
- (B) Lift the end cap and place the center nozzle into the center tube of the cartridge. Check the identification marks to ensure the end cap matches the correct end of the housing.
- Slowly slide the end cap in until it touches the outer O-ring (lumenside). Complete this step for both ends of the contactor.
- Rotate the end cap to align the marks placed on the end cap and the housing during disassembly.
- Place the V-Band clamp behind the clamping ridge of the housing. The clamp will need to remain there until the assembly process is complete.
- (C) Hook the assembly clips onto the end cap at both ends and adjust the nut for a secure fit. Repeat this step for the remaining assembly fixtures.
- Tighten nuts (2 rotations max at a time) to pull the end cap onto the cartridge. Tighten in an even manor that will allow the end cap to progress slowly and evenly. It will be necessary to do the tightening from both ends of the assembly arms during the installation process.
- Continue checking the alignment marks on the end caps and housing to properly align the end caps.

A

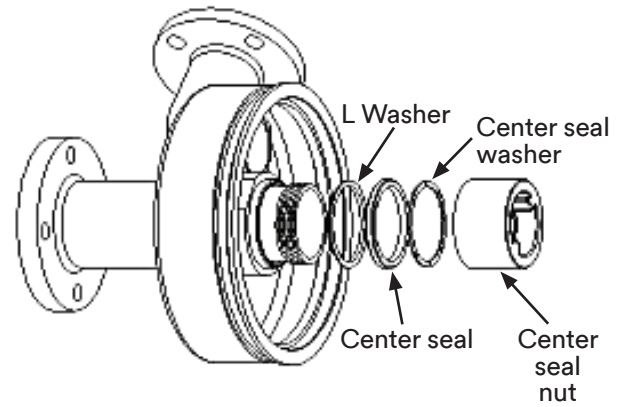

B

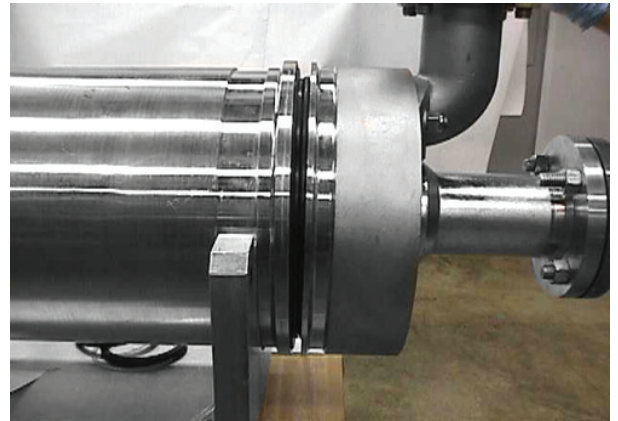

C

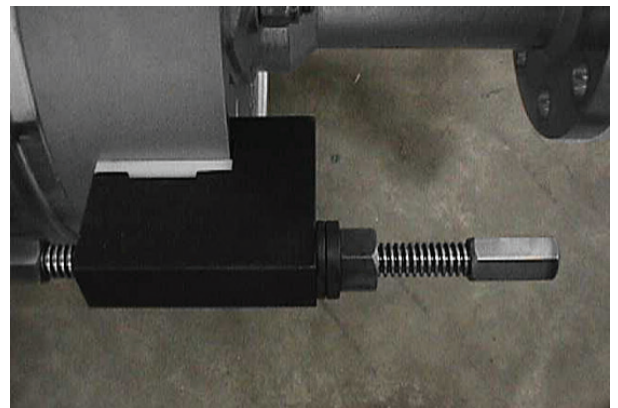

- (D) It is necessary to tighten in a pattern similar to the one shown on this picture. This will ensure that the end cap is inserted evenly.
- While the end cap is pulled tight against the housing, place the V-Band clamps on the ridges of housing and the end caps and tighten the clamps.
- Loosen the threaded rods of the assembly tool and disconnect the tool from the housing.

D

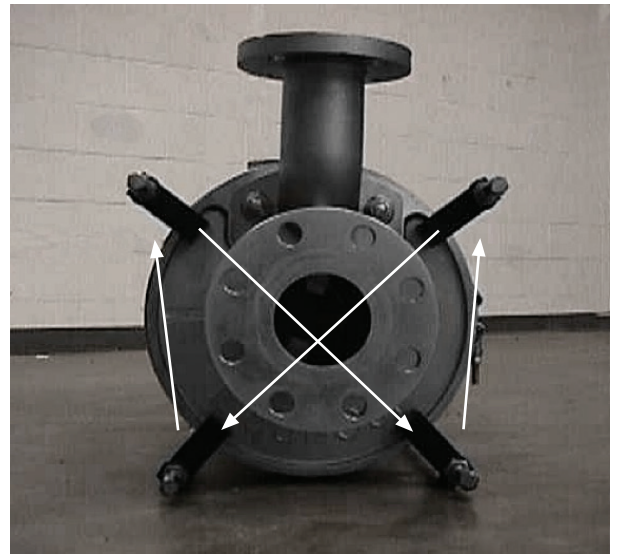

VACUUM INSERTION

- (E) Inspect and clean the sealing surface of both end caps.
- Place the L washer around the center nozzle and press down until it touches the cap nut.
- Place the center seal (see Assembly Part "d" on page 3) on the center nozzle. Press it over the threads and down against the L washer. Place the center seal washer (thinner washer) over the threads and against the center seal (see Assembly Part "e" on page 3). Screw the center seal nut onto the nozzle. Once it touches the washer, loosen it one turn.
- Bolt blind flanges on both lumen ports and one of the shell ports of the end caps.
- Lift the end cap and place center nozzle into center tube of the cartridge. Slowly slide the end cap in until it touches the outer O-ring (lumenside). Complete this step for both ends of the contactor.
- Rotate the end cap to align the marks placed on the end cap and housing during disassembly.

E

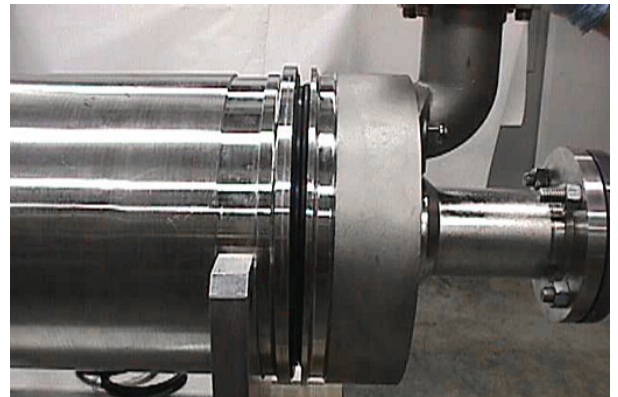
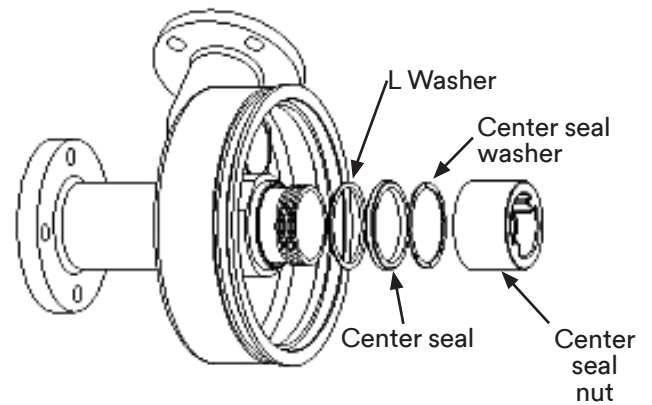

- (F) Bolt the vacuum flange onto to remaining shell port. Connect the vacuum hose to the flange and the vacuum.

F



- (G) Turn the vacuum pump on. Press the end caps against the O-rings.

G

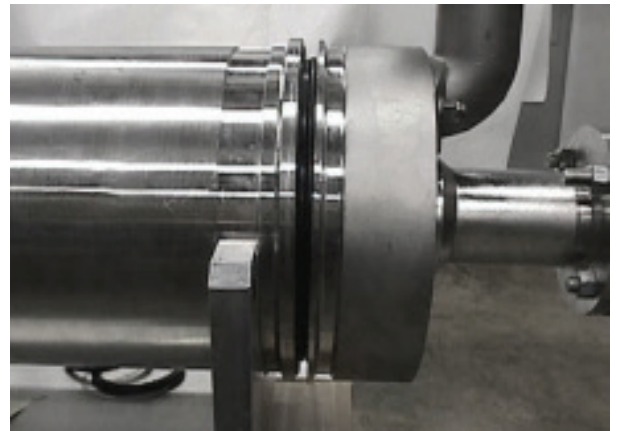

- (H) While the end cap is pulled tight against the housing, place the V-Band clamp on the ridge of the housing and the end cap and tighten the clamp. Repeat this step for the other end.

H

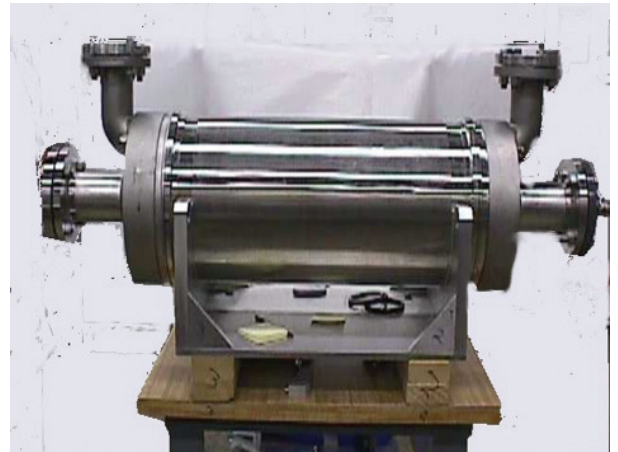

NOTE: Using ISO Ashby Cross oil on the nut will help get the nut on and off more easily.

- Turn off the vacuum. Remove the blind flanges from the shell connections and proceed to tighten the center seal.

CENTER SEAL TIGHTENING

- (I) Insert the center seal tool into the center nozzle. Turn the tool until you feel the notch in the tool mesh with the nubs of the center nut.
- Using a counter clockwise motion, slowly torque the center seal to 90 ft/lb. (122 Newton/meters). Repeat for other end.

I

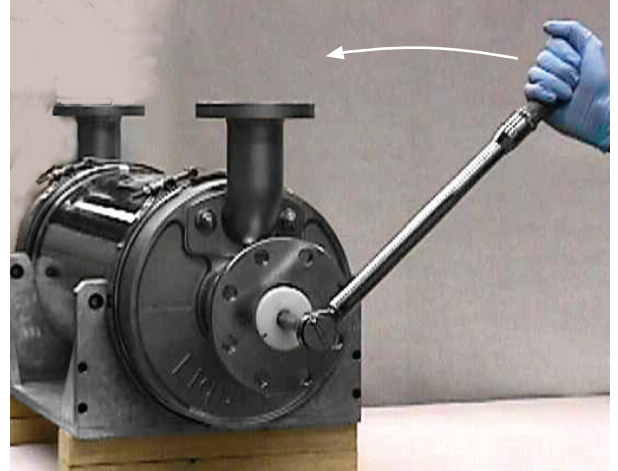

PRESSURE TEST

- (J) Bolt blind flanges on both lumen ports and one of the shell ports.
- Bolt a flange equipped with a 0-100 psi gauge and hose connection.
- Pressurize the housing to 60 psig with clean, oil free, air.
- Isolate the pressurized housing and monitor the pressure to verify a leak free seal. There should be no pressure decay over 30 minutes.

J

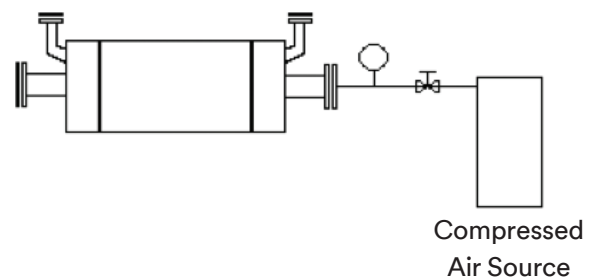

Technical Information: The technical information, guidance, and other statements contained in this document or otherwise provided by 3M are based upon records, tests, or experience that 3M believes to be reliable, but the accuracy, completeness, and representative nature of such information is not guaranteed. Such information is intended for people with knowledge and technical skills sufficient to assess and apply their own informed judgment to the information. No license under any 3M or third party intellectual property rights is granted or implied with this information.

Product Selection and Use: Many factors beyond 3M's control and uniquely within user's knowledge and control can affect the use and performance of a 3M product in a particular application. As a result, customer is solely responsible for evaluating the product and determining whether it is appropriate and suitable for customer's application, including conducting a workplace hazard assessment and reviewing all applicable regulations and standards (e.g., OSHA, ANSI, etc.). Failure to properly evaluate, select, and use a 3M product and appropriate safety products, or to meet all applicable safety regulations, may result in injury, sickness, death, and/or harm to property.

Warranty, Limited Remedy, and Disclaimer: Unless a different warranty is specifically stated on the applicable 3M product packaging or product literature (in which case such warranty governs), 3M warrants that each 3M product meets the applicable 3M product specification at the time 3M ships the product. 3M MAKES NO OTHER WARRANTIES OR CONDITIONS, EXPRESS OR IMPLIED, INCLUDING, BUT NOT LIMITED TO, ANY IMPLIED WARRANTY OR CONDITION OF MERCHANTABILITY, FITNESS FOR A PARTICULAR PURPOSE, OR ARISING OUT OF A COURSE OF DEALING, CUSTOM, OR USAGE OF TRADE. If a 3M product does not conform to this warranty, then the sole and exclusive remedy is, at 3M's option, replacement of the 3M product or refund of the purchase price.

Limitation of Liability: Except for the limited remedy stated above, and except to the extent prohibited by law, 3M will not be liable for any loss or damage arising from or related to the 3M product, whether direct, indirect, special, incidental, or consequential (including, but not limited to, lost profits or business opportunity), regardless of the legal or equitable theory asserted, including, but not limited to, warranty, contract, negligence, or strict liability.

3M and Liqui-Cel are trademarks of 3M Company. All other trademarks are the property of their respective owners. © 2021 3M Company. All rights reserved.



3M Company
3M Separation and Purification
Sciences Division
13840 South Lakes Drive
Charlotte, North Carolina 28273
USA
Phone: +1 980 859 5400

3M Deutschland GmbH
3M Separation and Purification
Sciences Division
Öhder Straße 28
42289 Wuppertal Germany
Phone: +49 202 6099 - 0

LC-1088
Rev. 04/2021

3M.com/Liqui-Cel