

# Optimized Deaeration System for Paulaner Brewery

The Centec DGS System is a modular, water deaeration process that uses hydrophobic Hollow Fiber Membrane to remove dissolved gasses from liquids in the beverage industry. This technical brief covers the unit's design, operation and resulting reduction of energy consumption costs.

Gas transfer starts with the basic principle that the concentration of dissolved gasses in water is proportional to the partial pressure of these gasses in contact with the liquid (Henry's law, Diagram 1).

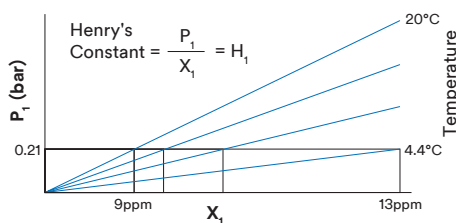

**Figure 1:** Henry's law:  $P_1 = H_1 \cdot X_1$ ;  $P_1$  = Partial pressure of the gas,  $H_1$  = Henry-constant,  $X_1$  = concentration of dissolved gas.

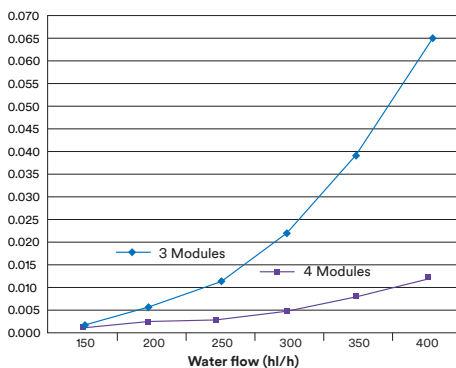

**Figure 2:** Influence of surface area in relation to flow-rate at constant water temperature with 3M™ Liqui-Cel™ 10" Module.

In this scenario, the partial pressure of oxygen at atmospheric condition is 0.21 bar (3 psi). If the partial pressure of gases in contact with the water changes, then the partial pressure of the oxygen in the water will also change.

## Deaeration Using Hollow Fiber Membranes

3M™ Liqui-Cel™ Membrane Contactors create a very large surface area within a small volume. Membrane degasifiers use a hollow fiber membrane to provide the surface area for the liquid and gas phases to come in contact with each other. Because the membrane is hydrophobic, the water will not pass through the membrane. Dissolved gasses, however, can easily pass through the membrane.

To obtain maximum gas transfer efficiency, a central baffle forces the liquid to flow radially over the membrane, which increases increasing the surface contact.

A vacuum is applied inside the hollow fiber with a small amount of CO<sub>2</sub> or N<sub>2</sub> sweep gas. Applying vacuum and sweep gasses reduces the partial pressure of the oxygen inside the hollow fiber to nearly zero. Because of the difference in the partial pressures, the dissolved oxygen in the water also decreases to virtually zero.

The gas and liquid phases try to reach equilibrium with each other. Because there is less O<sub>2</sub> in the gas phase, it will travel from the liquid phase to the gas phase and get carried away with the sweep gas and vacuum. This lowers the oxygen concentration in the water.

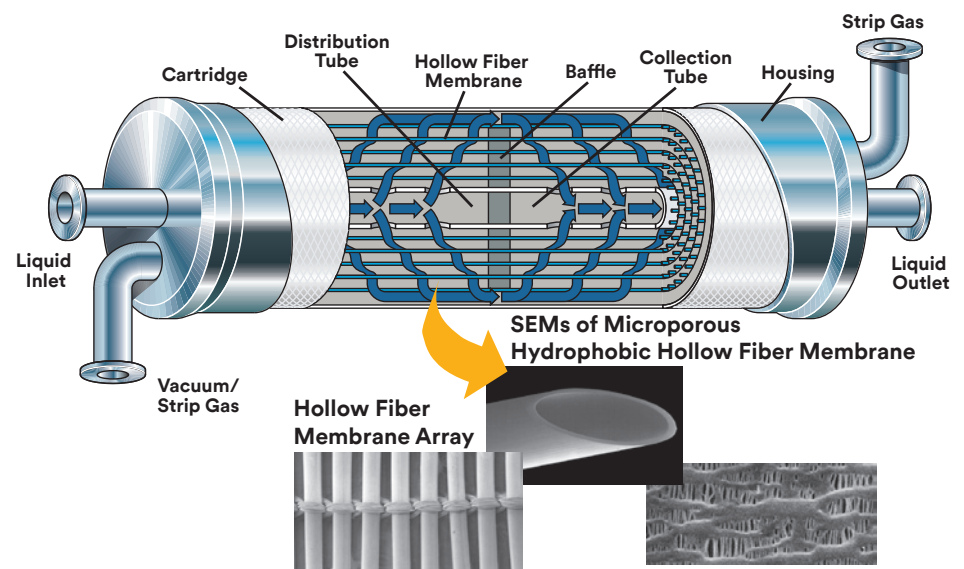

**Figure 3.** 3M™ Liqui-Cel™ Membrane Contactor

## The Deaeration System Using 3M™ Liqui-Cel™ Membrane Contactors

High oxygen levels in beer cause organoleptic problems in the final product, so the aim of this process is to achieve oxygen-free water, which can be used in several places throughout the beer production processes, such as:

- Pre-coating of filters
- Pre and post filtration runs
- Product chase through the pasteurizer
- Blending
- Production of beer-mix-beverages, etc.

After deaerating the water, it is important to ensure that no air leaks back into the system. Critical components that can add air back into the system include pumps with damaged mechanical seals or dairy flanges.

### Components of the Deaeration Unit

The following components were used in this deaeration unit at Paulaner Brewery:

- Booster pump for water: Make: Fristam, 40 m<sup>3</sup>/h, head: 8 bar, 18.5 kW
- Particle-filter: Make: Filtrox, Type Filtrap (30 x cartridges with a pore-size of 3 µm absolute);
- Hollow fiber membrane modules: Make: Centec, DGS. Using four 10-inch Liqui-Cel Degassing units,
- Vacuum-pumps: Make: Sihi, Lema 50, 4 × 1.5 kW,
- UV Disinfection unit: Make: Wedeco Katadyn, Type LBA 50 (1050 J/m<sup>2</sup>),
- Carbonization: Make: Centec, Vortex-Venturi-Injector DN 100,
- PLC: Make: Siemens, SPS S5 155 U, CPU 948
- MMI & Screen Overview: Make: Siemens, Dimos X 5.

**Table 1:** Residual oxygen content of water depending on flow-rate (Water: Temperature 14°C, Vacuum: 100 mbar, CO<sub>2</sub> consumption: 9.3 Nm<sup>3</sup>/h)

Flow-rate (hl/h)	Residual oxygen content (mg/l)
100	0.002
200	0.003
300	0.007
400	0.02

### Specification of the Residual Oxygen Content of Water

The degassing system was designed to achieve residual oxygen contents <0.02 mg/l (ppm) at a water temperature of 14°C and maximum flow-rate of 400 hl/h.

The control of the unit was based on the level of the water buffer-tank which controlled the frequency converter of the water feed pump.

The system is capable of operating at lower flow rates if low amounts of water are required to fill the buffer tank.

At lower flow rates, the deaeration process is more efficient as more time is available to deaerate the water in the degassing modules. As a result, lower than originally planned residual oxygen contents were achieved. (See Table 1.)

### Reduction of Electrical Energy Consumption

The number of pumps required for the operation is dependant on the flow rate through the deaeration system.

If only small quantities of water are required, then the throughput of the deaeration system is also reduced. The applied vacuum, together with the sweep gas, has an important influence on the deaeration efficiency. Vacuum pumps can be switched on / off depending on flow rates.

**Table 3:** CO<sub>2</sub> consumption depending on temperature

Water Temperature (°C)	Flow – rate (hl/h)	CO <sub>2</sub> consump. (Nm <sup>3</sup> /h)
12	400	ca. 10.0
14	400	ca. 9.3
16	400	ca. 8.7
18	400	ca. 8.1
20	400	ca. 7.5

At the outlet of the unit, an oxygen probe is installed. Depending on flow rate and the measured residual oxygen content, either two, three or four vacuum pumps are used in the operation.

### Reduction of CO<sub>2</sub> Consumption

As described above, the CO<sub>2</sub> consumption is dependent on the flow rate and the oxygen content of the feed water. This is related to the amount of operating vacuum pumps. An oxygen probe, installed at outlet of the unit, controls CO<sub>2</sub> consumption.

At this stage we also must be aware of the system limits to avoid cavitation of the vacuum pumps.

### Modular Design of the Unit and Expandability

This deaeration system was designed for a capacity of 400 hl/h and is expandable up to 600 hl/h.

To expand the system, two additional membrane contactors and one additional vacuum-pump would be required. Two rows of modules would be operated in parallel, each equipped with three modules in series.

### Cleaning (CIP) of the Unit

The hollow fiber Liqui-Cel membrane contactors can be cleaned at temperatures of 85°C. For cleaning food-grade units, caustic soda and phosphoric acid can be used with concentration ranges of 1 to 3%.

**Table 2:** CO<sub>2</sub> consumption depending on flow rate

Flow-rate (hl/h)	CO <sub>2</sub> consumption (Nm <sup>3</sup> /h)
100	ca. 10.0
200	ca. 9.3
300	ca. 8.7
400	ca. 8.1

No surfactants or additives should be used in either the caustic or the acid. The frequency of CIP depends on the number of hours in operation and microbiological results.

At Paulaner Breweries a monthly CIP is completed. The piping of the unit was designed to allow the UV system to be cleaned separately (in order to keep UV-lamps clean) by bypassing the membrane modules.

The membranes are further protected by a temperature transmitter, at the inlet of the unit to ensure that the CIP fluid temperature is <85°C otherwise the CIP fluid will bypass the system.

## Wrap-up and Final Notes

The degassing unit described has been running since October of 2003. The unit has operated completely problem- and maintenance-free since installation.

During the operation of the system the control philosophy, in terms of the reduction of running costs, has been optimized. The additional investment costs outlaid for the optimization of the energy operation have been negligible (control valve, pressure reducer, rotary flow meter with signal output, additional programming).



Figure 5: The Water Deaeration System DGS 400 has been in operation since October 2003 and has not required problem solving or maintenance.

For additional information, please contact your 3M representative or visit [3M.com/Liqui-Cel](http://3M.com/Liqui-Cel).

Figure 4: Schematic P&ID of the unit

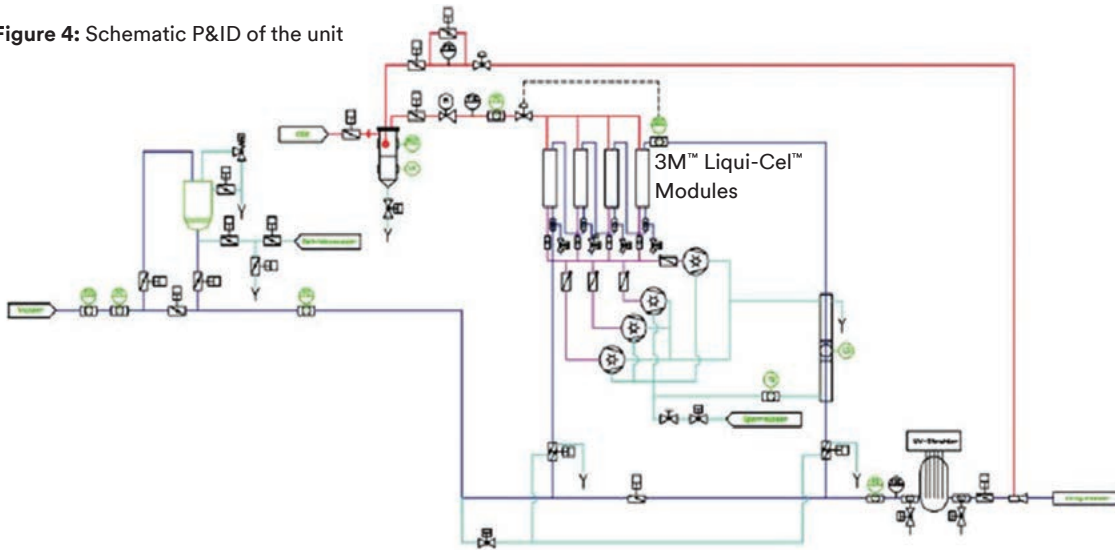

This publication is produced in cooperation with Centec GmbH, Germany.

**Technical Information:** The technical information, guidance, and other statements contained in this document or otherwise provided by 3M are based upon records, tests, or experience that 3M believes to be reliable, but the accuracy, completeness, and representative nature of such information is not guaranteed. Such information is intended for people with knowledge and technical skills sufficient to assess and apply their own informed judgment to the information. No license under any 3M or third party intellectual property rights is granted or implied with this information.

**Product Selection and Use:** Many factors beyond 3M's control and uniquely within user's knowledge and control can affect the use and performance of a 3M product in a particular application. As a result, customer is solely responsible for evaluating the product and determining whether it is appropriate and suitable for customer's application, including conducting a workplace hazard assessment and reviewing all applicable regulations and standards (e.g., OSHA, ANSI, etc.). Failure to properly evaluate, select, and use a 3M product and appropriate safety products, or to meet all applicable safety regulations, may result in injury, sickness, death, and/or harm to property.

**Warranty, Limited Remedy, and Disclaimer:** Unless a different warranty is specifically stated on the applicable 3M product packaging or product literature (in which case such warranty governs), 3M warrants that each 3M product meets the applicable 3M product specification at the time 3M ships the product. 3M MAKES NO OTHER WARRANTIES OR CONDITIONS, EXPRESS OR IMPLIED, INCLUDING, BUT NOT LIMITED TO, ANY IMPLIED WARRANTY OR CONDITION OF MERCHANTABILITY, FITNESS FOR A PARTICULAR PURPOSE, OR ARISING OUT OF A COURSE OF DEALING, CUSTOM, OR USAGE OF TRADE. If a 3M product does not conform to this warranty, then the sole and exclusive remedy is, at 3M's option, replacement of the 3M product or refund of the purchase price.

**Limitation of Liability:** Except for the limited remedy stated above, and except to the extent prohibited by law, 3M will not be liable for any loss or damage arising from or related to the 3M product, whether direct, indirect, special, incidental, or consequential (including, but not limited to, lost profits or business opportunity), regardless of the legal or equitable theory asserted, including, but not limited to, warranty, contract, negligence, or strict liability.

3M and Liqui-Cel are trademarks of 3M Company. All other trademarks are the property of their respective owners. © 2021 3M Company. All rights reserved.



3M Company  
3M Separation and  
Purification Sciences Division  
13840 South Lakes Drive  
Charlotte, North Carolina  
28273 USA  
Phone: +1 980 859 5400

3M Deutschland GmbH  
3M Separation and  
Purification Sciences Division  
Öhder Straße 28  
42289 Wuppertal Germany  
Phone: +49 202 6099 - 0

LC-1076  
70-2016-0230-0

Rev. 02/2021

[3M.com/Liqui-Cel](http://3M.com/Liqui-Cel)